

INSTALLATION INSTRUCTIONS
DESCRIPTION: Soft Sun Top Kit
PART NUMBER: 2PG-K830V-V0 (Black)
MODEL: 2015 Viking VI



⚠ WARNING

Please read and understand these instructions completely before installation to avoid possible injury, or damage to the accessory or vehicle.

NOTICE:

This installation requires a torque wrench and should be performed by an authorized Yamaha dealer or other qualified technician.

WARRANTY INFORMATION:

Genuine Yamaha accessories are covered by a one-year limited warranty against defects in material or workmanship. Labor for replacement of defective components is not covered. See your Yamaha dealer for a copy of the limited warranty statement.

DEALER OR INSTALLER:

These instructions contain important information for future reference and *must* be given to the customer.

PARTS LIST:

No.	Part Number	Description	Qty
--	2PG-K830V-V0	Soft Sun Top Kit	--
①	*	Sun Roof Cover	1
②	*	Hook Strap	2
③	*	Buckle Strap	2
④	*	Rear Bow (60")	1
⑤	*	Front Bow (52")	1
⑥	*	Center Bow (48")	1
⑦	*	Button Head Bolt (4mm)	4
⑧	*	Washers	4
⑨	*	Bow End Bracket	4
⑩	*	Front Bow Clamp (Large Opening)	2
⑪	*	Center Bow Clamp (Small Opening)	2
⑫	*	Strap Sleeve with hook-and-loop closure	5

* Part supplied with kit only and not available separately.

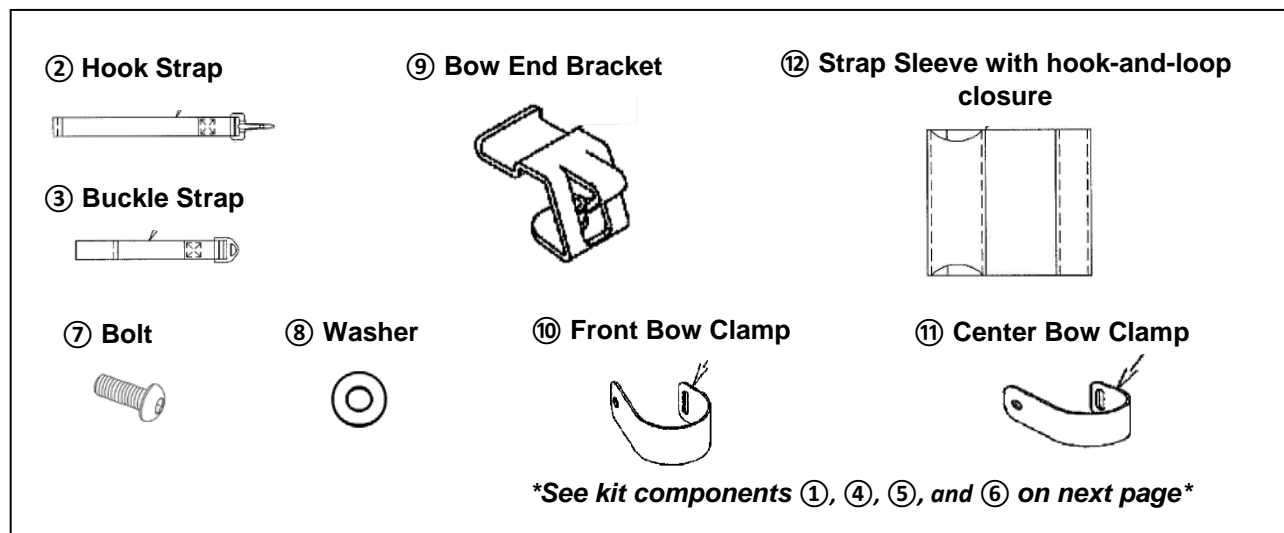

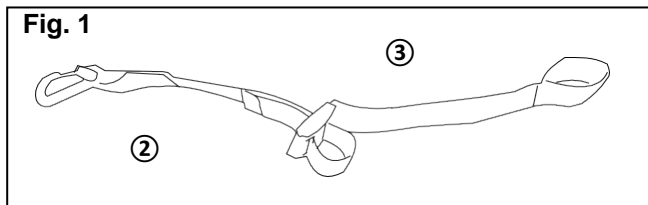
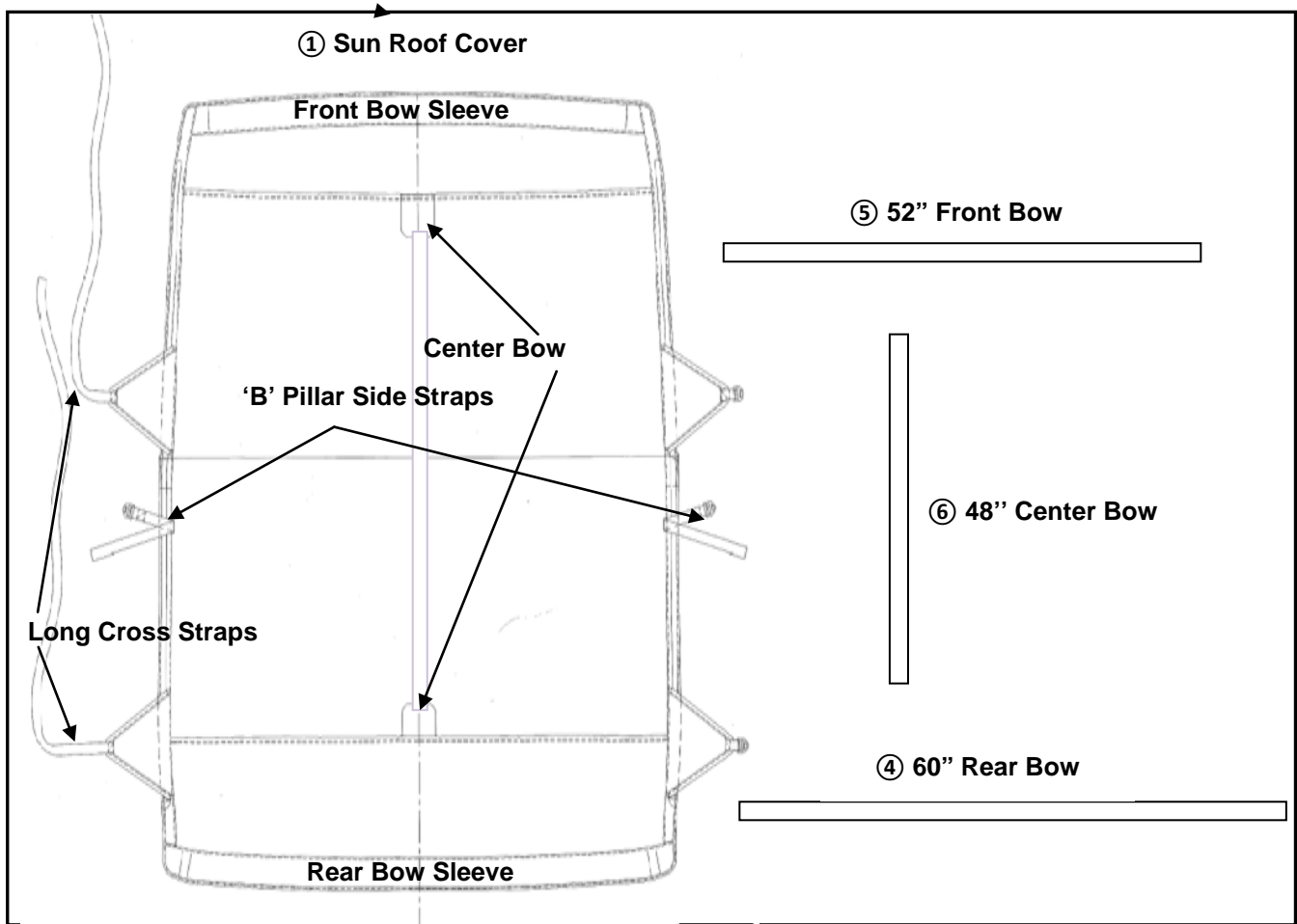

PREPARATION:

1. Place vehicle on a secure and level surface.
2. Set the parking brake.
3. Clean all mounting surfaces before beginning installation.

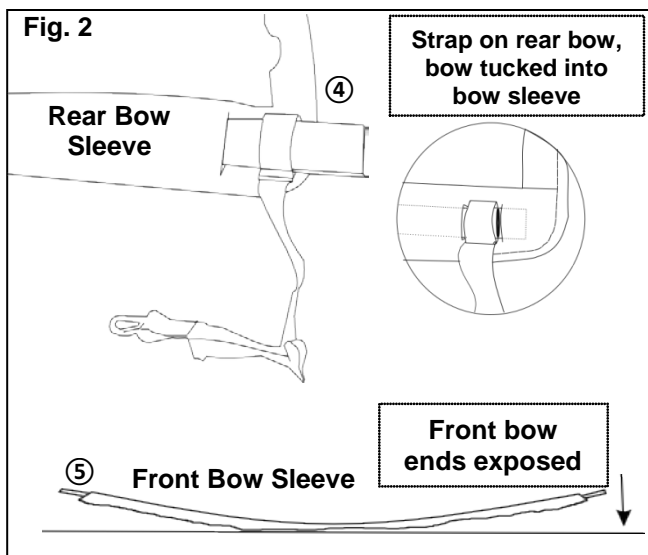

INSTALLATION:

1. Build two retaining strap assemblies by joining a Hook Strap ② to a Buckle Strap ③. Thread Hook Strap end through the adjuster on the Buckle Strap (see Fig.1).
2. Unfold the Sun Roof Cover ①, black side down. Insert the Rear Bow ④ into the Rear Bow Sleeve. (see Fig. 2).
3. Slide an open loop of a retaining strap assembly over one of the rear bow ends. Then, slip the bow end into the rear bow sleeve to lock the strap to the bow. Repeat procedure on opposite side (Fig. 2).

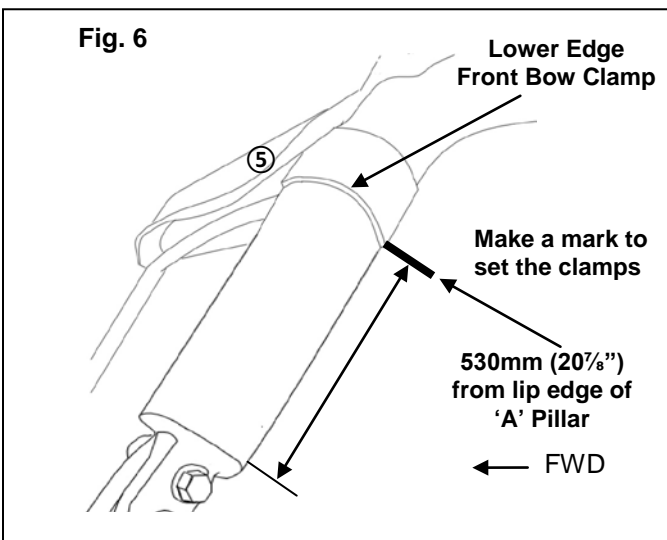
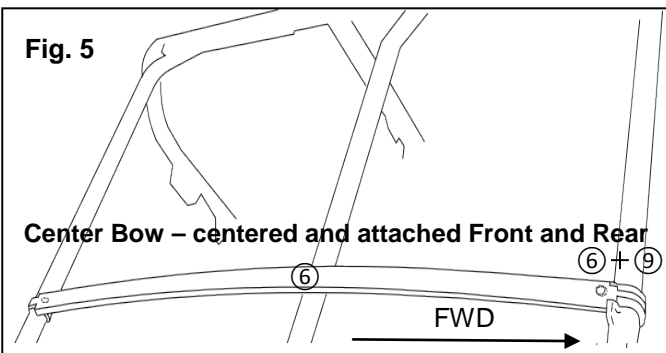
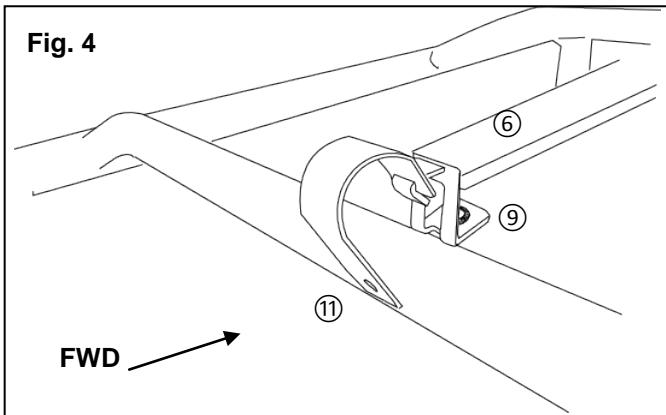
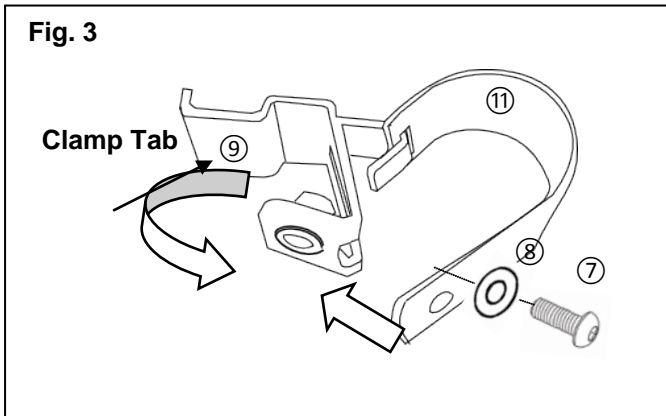

4. Slide the Front Bow (5) into the Front Bow Sleeve. The bow ends will extend beyond the sleeve (see bottom of Fig. 2).
5. Hook a Bow End Bracket (9) onto a Center Bow Clamp (11) (see Fig. 3).
6. Place the clamp around the rear crossbar and center the bracket/band on the crossbar. Pinch the band and bracket together. Thread a bolt (7) and washer (8) through the band and into the bracket (be careful not to cross thread the bolt). Leave slack on the band to adjust its position along the crossbar. (see Fig. 4).
7. Hook the other Center Bow Clamp (11) onto a Bow End Bracket (9). Press the bracket/clamp onto the end of the Center Bow (6). Press the open clamp with the Center Bow attached onto the front crossbar. Put some upward pressure on the Center Bow as you press the clamp onto the bar. Close the clamp and insert and torque the bolts to 7 ft • lb (Fig. 5).

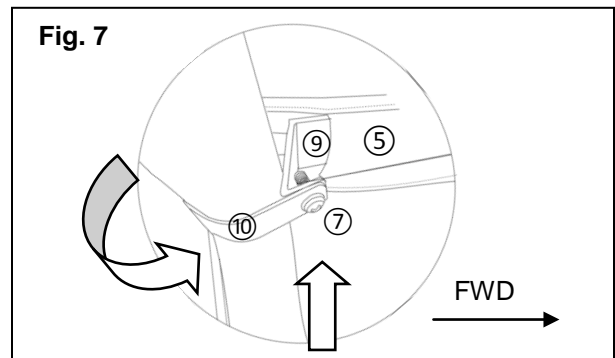

8. Go to the front of the vehicle. Measure and mark a line on both 'A' Pillars. This mark should be 530mm (20⁷/₈"") from the lip edge. (see Fig. 6).
9. Hook a Bow End Bracket (9) through the slot in the Front Bow Clamp (10). Wrap the open end of one clamp around the 'A' Pillar tube (with the bracket facing the inside). Position the band directly above the 530mm (20⁷/₈"") mark. Tighten the clamp (see Fig. 6 and Fig. 7).
10. Place the Sun Roof Cover (1) over the roof supports. The Front Bow is in the front bow sleeve. Go to the front of the vehicle and insert the tab of the Front Bow Clamp (10) installed in Step #9 into an open end of the Front Bow (5).

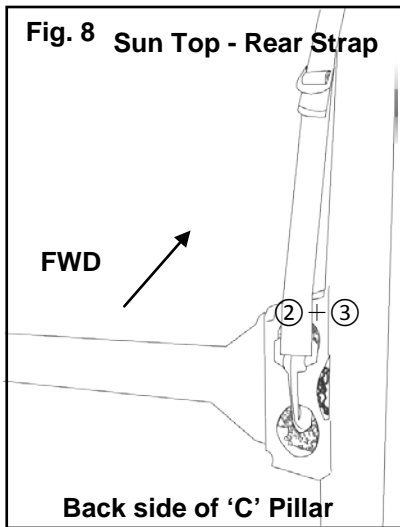
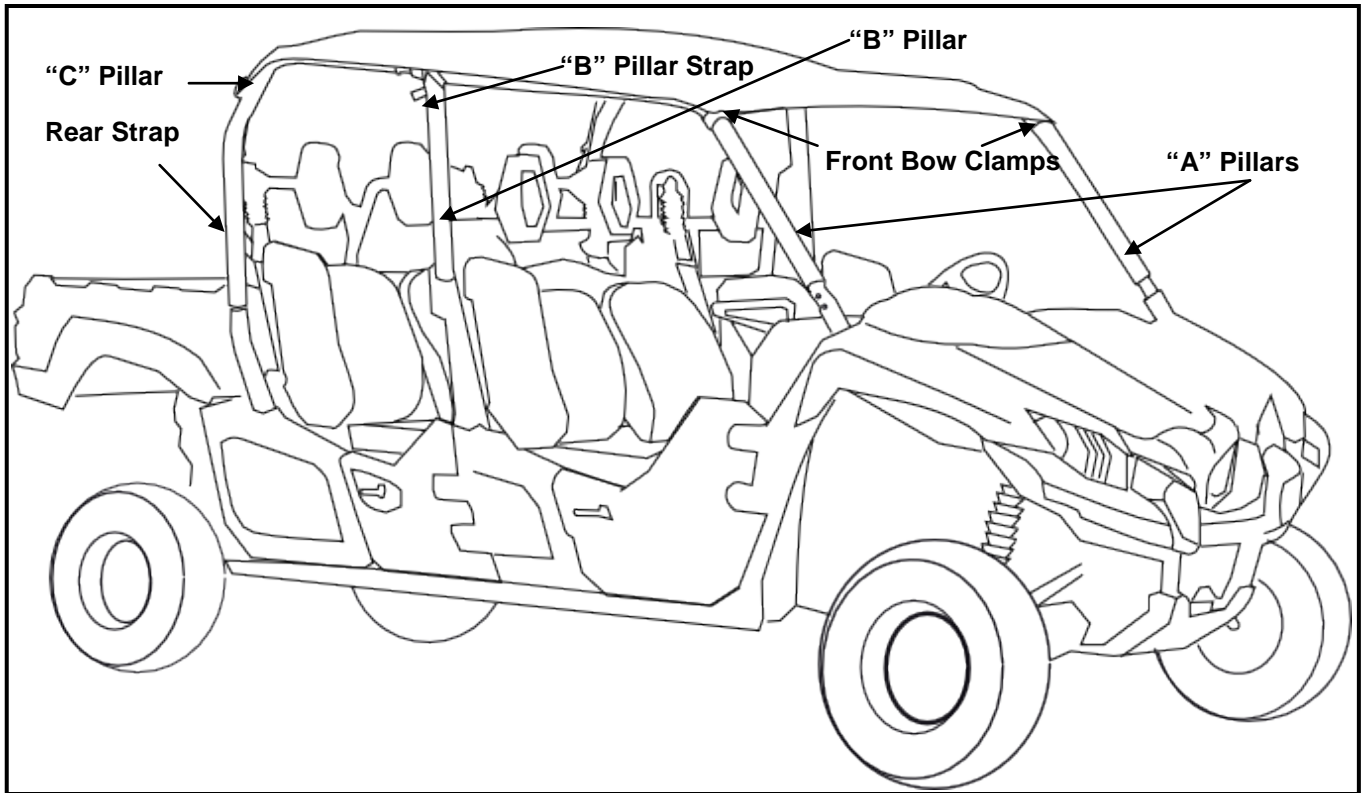

(Step #10 cont'd.)

Do the same on the other side of the vehicle. Press the open clamp over the 'A' Pillar and center the top. Torque the bolts on the clamps to 7 ft • lb (see Fig. 7).

11. Go to the rear of the vehicle. Hook the rear roof straps onto the rear seat belt brackets. Check that the Sun Roof Cover ① is centered as you cinch up the soft straps (see Fig. 8).
12. Slide three (3) strap sleeves ⑫ onto the cross strap (see Ⓐ in Fig. 9).
13. Slide two (2) strap sleeves ⑫ onto the rear cross strap (see Ⓑ in Fig. 9).

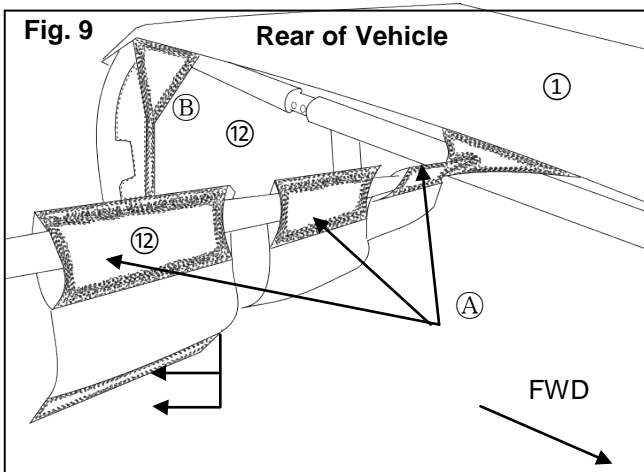

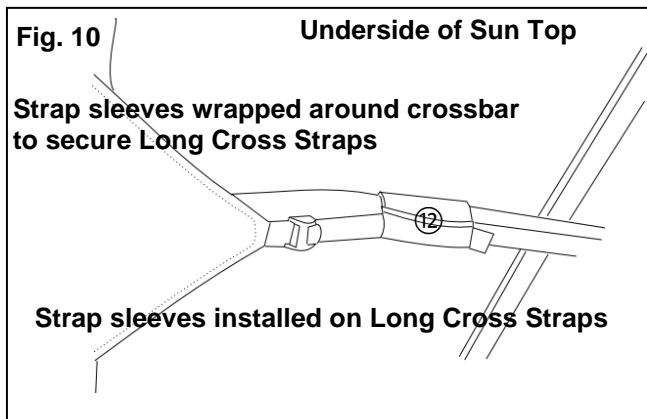

14. Working inside the vehicle, feed the loose ends of the straps into the buckles on the opposing sides and cinch tight. Equally space the strap sleeves along the strap then wrap the sleeves around the tube, and secure using the hook-and-loop fasteners (see Fig 10).

15. Wrap remaining side straps around the top of the 'B' Pillar and thread the loose end of the strap through the buckle and cinch tight (see Fig. 11).

NOTICE:
 Remove the Soft Sun Top if the vehicle is going to be towed on a trailer on public roads.

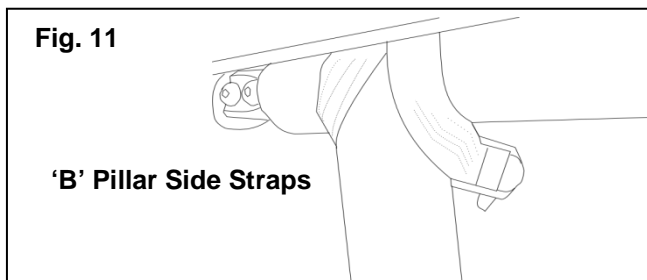

MAINTENANCE:
 Fading can occur if stored in direct sunlight for extended periods of time. Remove as necessary.

CARE AND CLEANING:
 Spot clean using a mild soap and water solution and soft cloth. Let top air dry.

CUSTOMER SERVICE:
 For further information see your Yamaha dealer.

ESTIMATED TIME TO INSTALL: 0.5 HRS